

# Air sifter

## Plain air sifter

Plain air sifter consist of a blowing hood and a sucking hood.

Light material like foils and paper is separated from heavy material. Air sifter with variable capacity of blowing and sucking can be used e.g. in foil and paper separation.

A presorting of big foils is mostly unnecessary, because they are unproblematic to process.

## Closed air sifter

Closed sifters are mainly used in the LVP-sorting (fine grit, medium size grit, oversized grit sorting), construction waste and processing of substitute fuel. Mechanical/organic preparation is another new field.

Closed air sifters equipped with a separation part can sort three materials automatically.

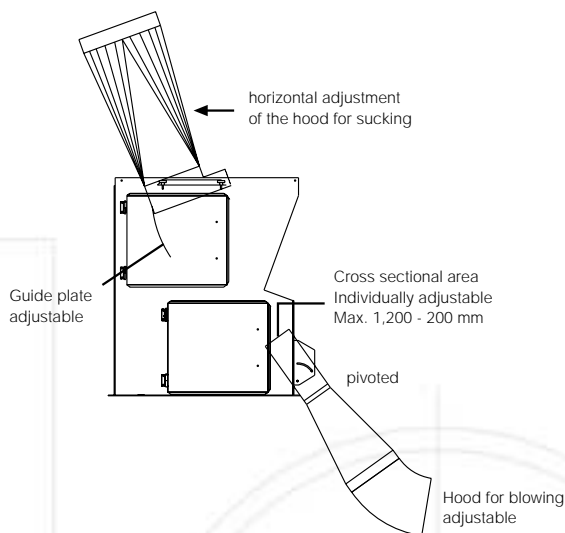

## Always the right adjustment

Hoods for blowing and sucking are variable adjustable. They can be set for a variety of different systems. The examined good enters via material opening with vibration channel or conveyor belt the separator. Depending on the specific task, the guide plates are either fixed or flexible. The separation fits every individual task.

It can also be used as a simple sucking separator fixed to a conveyor screen, a star like screen or disc screen for the processing of compost and street rubbish. Light materials, normally foils an paper, are separated from the organic material.

**What is your special work for NESTRO-Air-Sifters?  
We are looking forward to answer your enquiry  
and your arrangement for an appointment.**

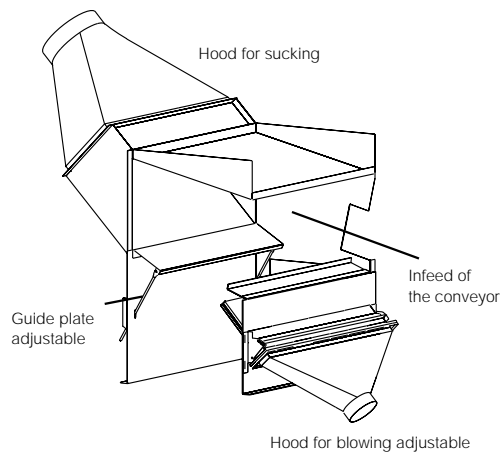

## Three times benefit

First, the light material (foil, paper) is lifted pneumatically, and vacuumed up. Second, a stronger air stream that blows and separates the material in the middle (wood, plastics rests) from the remaining air stream. The material is transported by a conveyor belt with separator part to the designated storage containers. The heavy material (glass, ceramics, stone, concrete rests) is collected at the end of the line.

**NESTRO** Lufttechnik GmbH

**D - 07619 Schkölen**  
Hainchen / An der Wethau 1  
Telephone + 49 (0) 36694 41 - 0  
Telefax + 49 (0) 36694 41 - 260

**D - 63934 Röhlbach**  
Odenwaldring 9  
Telephone + 49 (0) 9372 137 - 0  
Telefax + 49 (0) 9372 137 - 260

[www.nestro.de](http://www.nestro.de)

**D - 33775 Versmold**  
Speckstraße 13  
Telephone + 49 (0) 5423 9492 - 0  
Telefax + 49 (0) 5423 9492 - 29

**A - 4840 Vöcklabruck**  
Wartenburgerstrasse 31  
Telephone + 43 (0) 7672 75707 - 0  
Telefax + 43 (0) 7672 75707 - 40

[info@nestro.de](mailto:info@nestro.de)

**PL - 46 - 380 Dobrodzień**  
ul Ks Gładysza 10  
Telephone + 48 (0) 34 353 - 6357  
Telefax + 48 (0) 34 353 - 6347

**H - 7635 Pécs**  
Fábán B. út. 8  
Telephone + 36 (0) 72 216461  
Telefax + 36 (0) 72 510482

# NESTRO®

## Air sifter – a jack-of-all-trades

### Facts:

- automatic separation with a separation part in up to three groups of material
- variable, independent capacity of blowing and sucking
- Presorting of big foils is unnecessary
- Closed type for LVP-sorting, construction waste, processing of substitute fuel



**Components ■ Products ■ Systems ■ Service**